

LOC	DIST	REVISIONS			
HM	00	REV	DATE	BY	APPD
		A	11OCT2005	GG	PP
		B	11JAN2006	GG	DC
		C	11MAR2008	LH	DC

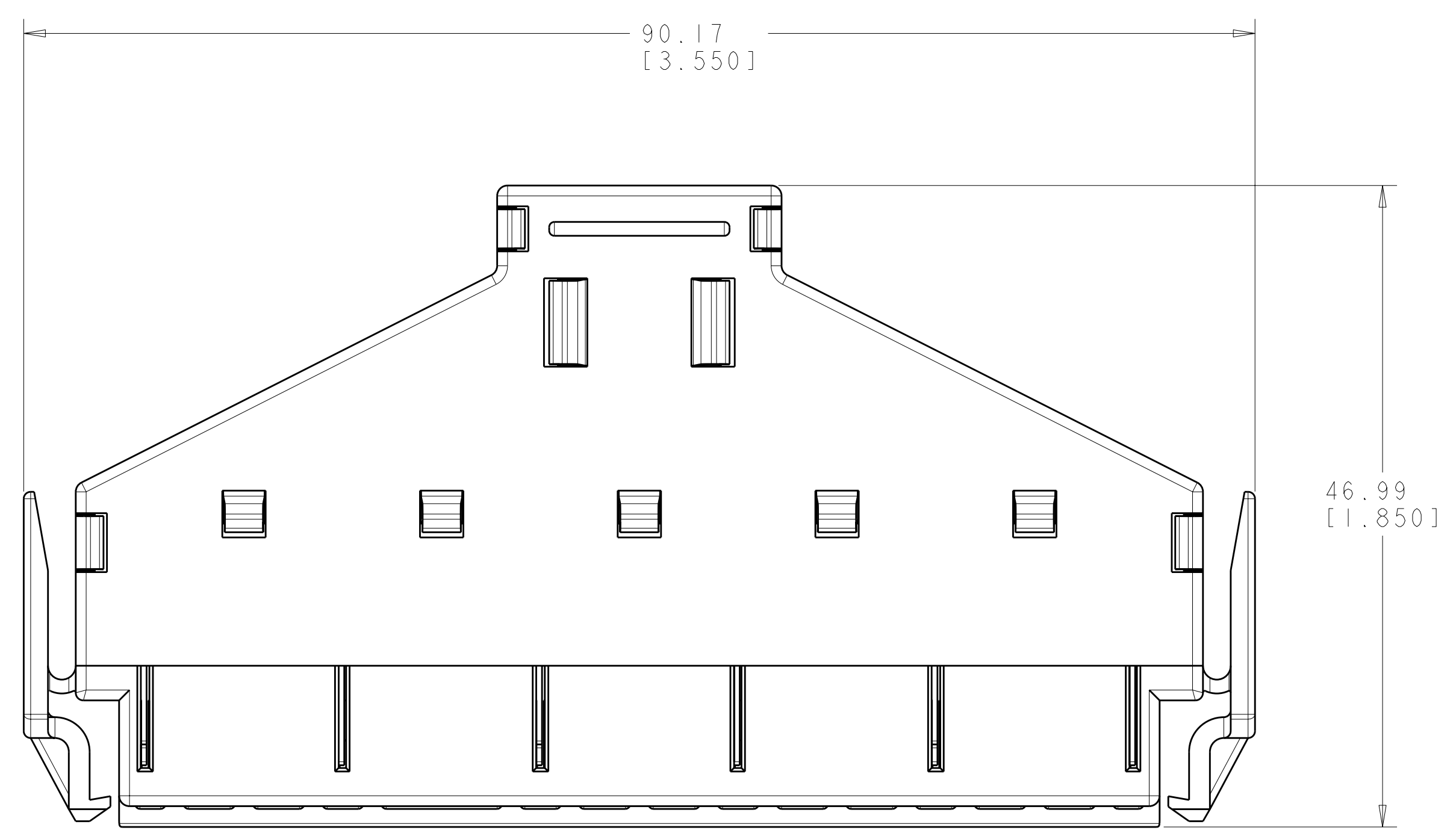

- 1 MATERIAL:
 BASE AND COVER - POLYCARBONATE MOLDING COMPOUND, BLACK.
 TERMINAL PAIR - PHOSPHOR BRONZE.
 PLATED WITH 0.0038 [0.000150] MINIMUM THICK
 MATTE TIN PER TYCO ELECTRONICS SPEC 112-65-1 OVER
 0.00127-0.00330 [0.000050-.000130] THICK NICKEL UNDERPLATE.
- 2 ALL DIMENSIONS SHOWN ARE NOMINAL.
3. KIT SHIPPED NOT ASSEMBLED.

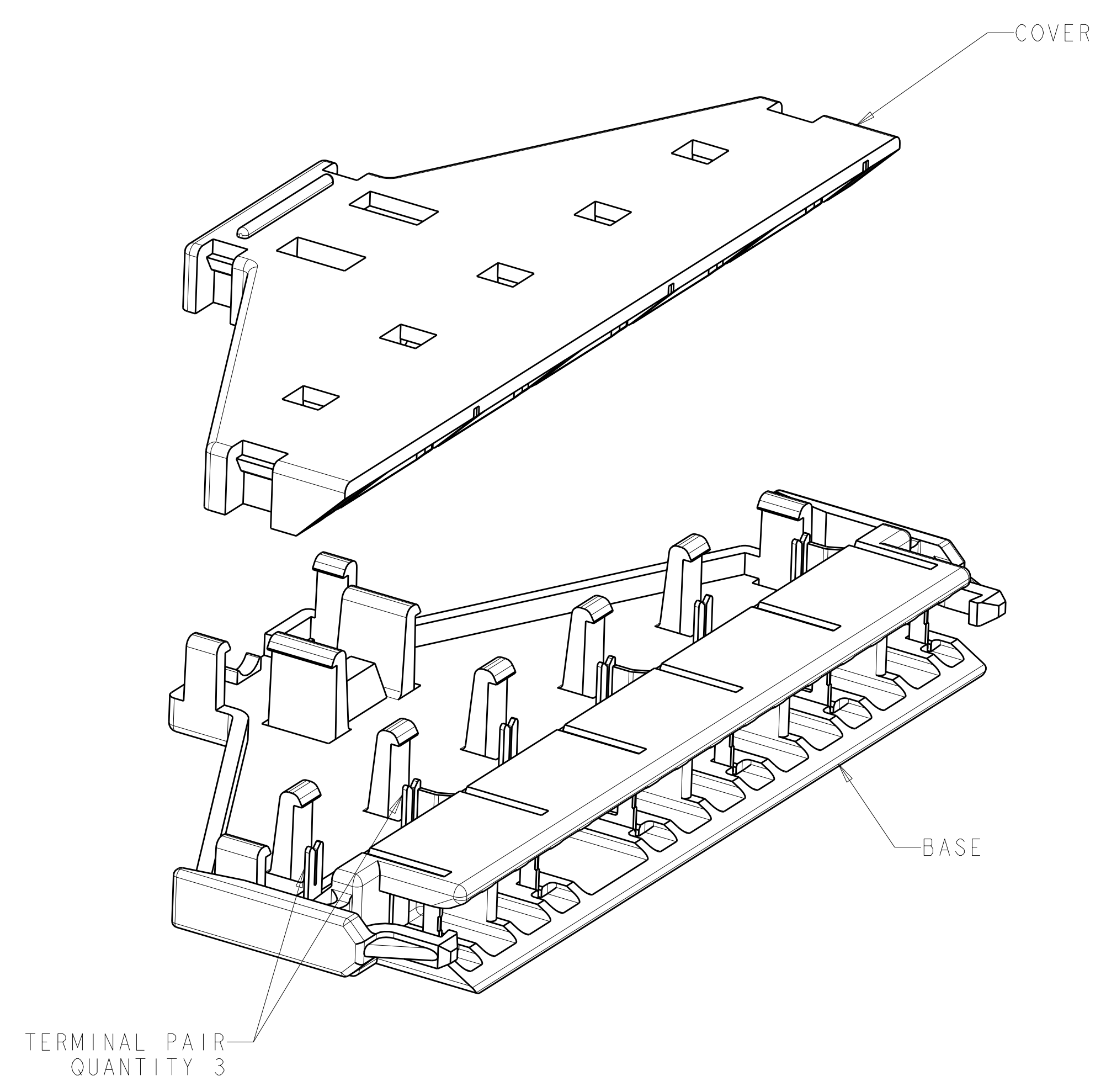
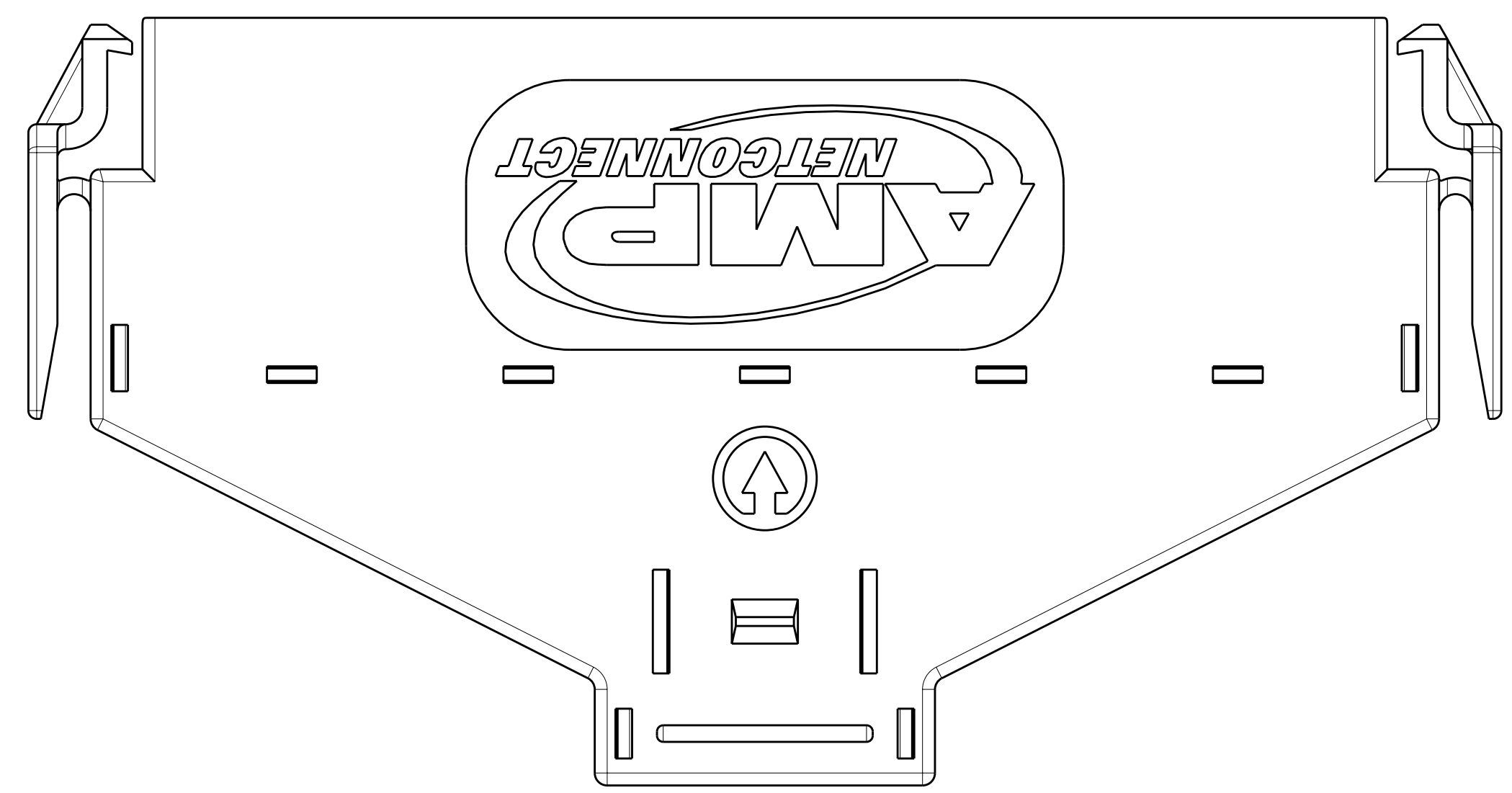
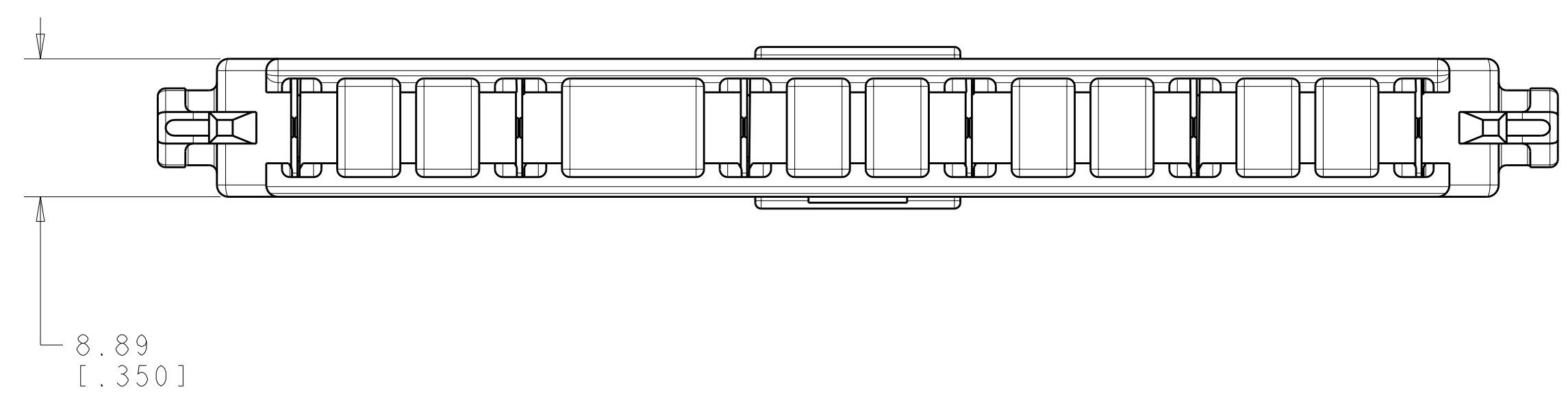

1479960-1
PART NUMBER

DIMENSIONS: MM [INCHES]		TOLERANCES UNLESS OTHERWISE SPECIFIED:		DWN GS GARRETT 11OCT2005		Tyco Electronics Harrisburg, PA 17105-3608	
9 PLC ± .1 1 PLC ± .1 2 PLC ± .1 3 PLC ± .1 4 PLC ± .1 ANGLES ± .1		± .1 ± .1 ± .1 ± .1 ± .1 ± .1		CHK P PEPE 11OCT2005		NAME KIT, PLUG, I/O, 110 CONNECT	
MATERIAL:		FINISH:		APVD P PEPE 11OCT2005		PRODUCT SPEC:	
± .1		-		APPLICATION SPEC:		SIZE CAGE CODE DRAWING NO. RESTRICTED TO	
-		-		WEIGHT:		A100779C=1479960	
-		-		CUSTOMER DRAWING		SCALE 3:1 SHEET 1 OF 1 REV C	